

1 General

Model CST7 digital flux meter, employing electronic integrator and digital display, consists of principal meter and sensing coil. The flux meter can measure accurately the magnetic flux from magnetic objects and of pulse field. As one of the most useful measuring instruments in magnetic measuring areas, the fluxmeter can be not only used for regular flux measurement of various magnetic materials (except for ring magnet) but also suitable for magnetic product producers to test and control the product quality. Meanwhile, Model CST7 fluxmeter possesses peak-holding function, picking up quantitatively the instantaneous pulse field, which proves to be uniquely advantageous. In addition, the fluxmeter features a low shift, clear display, artistic appearance and ease in operation, which makes itself an ideal instrument for flux measurement.

2 Specifications and Operation Conditions

2.1 Measurement Range:0~2Wb

Measurement full scale: 1000 word

Multiplier (Wb)		10^{-3}	10^{-2}	10^{-1}	1
Applicable Range (Wb)		$0\sim 2 \times 10^{-3}$	$0\sim 2 \times 10^{-2}$	$0\sim 2 \times 10^{-1}$	0~2
Valid Range		$10^{-3}\sim 10^{-3}$	$10^{-4}\sim 10^{-2}$	$10^{-3}\sim 10^{-1}$	$10^{-2}\sim 1$
Accuracy		$\pm 1\% \text{ FS} + 1 \text{ word}$			
Sensitivity (Wb)		10^{-6}	10^{-5}	10^{-4}	10^{-3}
Stability	Short time (10s)	$\pm 5 \text{ word}$			
	Long time (1min)	$\pm 30 \text{ word}$			
Overload (%)		100%			
Input Impedance(k Ω)		10	100	1000	10000

2.2 Operating Condition

Temperature Range:5~40°C

Humidity Range: 20~80%

Power Supply: 220 V AC

2.3 Display Mode: 3.5 bit LED, with positive and negative polarity automatically displaying

2.4 230X291X70mm

2.5 Weight: 2 kg

2.6 Prewarming Time: 30 min

2.7 Voltage Endurance: 1.5 kV

2.8 Packing and Transportation Conditions;'

Temperature:-25~55°C

Humidity: 20~80%

2.9 Appearance:

No obvious deformation and damage in cover, the marks and symbols on the front and rear panel are clear to be recognized, and no mechanical uptightness in whole machine.

3 Working Principle

Model CST7 digital fluxmeter employs sensing coil and electronic integrator to test the magnetic flux.

Suppose the sensing coil coefficient to be NA , where N is sensing turns, and A sensing area in square millimeter, the magnetic induction strength, or magnetic flux density measured to be B in Tesla, and the flux over the sensing area to be Φ . The

change of Φ with time will produce an inductive voltage V in the sensing coil:

$$V = d\Phi/dt \quad (1)$$

$$\text{While } \Phi = BA \text{ (Wb)} \quad (2)$$

From (1), we can get by integration:

$$\varphi = 1/N * \int V dt \quad (3)$$

By using electronic integrator the inductive signal voltage can be integrated and flux Φ obtained.

4 Operations

4.1 Illustration

All the operating keys or buttons are installed in the front panel of the fluxmeter

All the operating keys or buttons are installed in the front panel of the fluxmeter

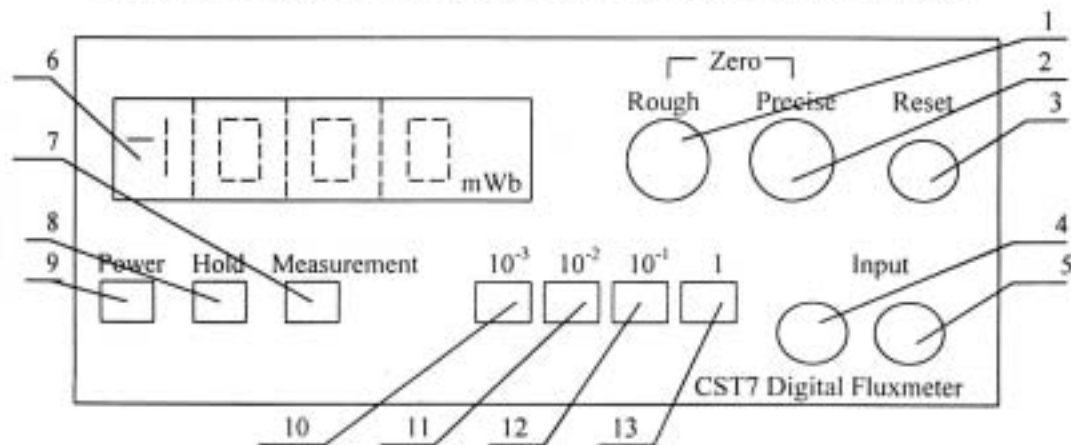

- (1) Rough adjustment potentiometer: for rough zero setting of zero input.
- (2) Precise adjustment potentiometer: for precise zero setting of zero input.
- (3) Resetting: for reading resetting
- (4) Positive end of input: for input signal
- (5) Negative end of input: for input signal
- (6) Screen, 3.5 bit read display

- (7) Measurement button: when pressing down this button, the fluxmeter is ready for signal integrating measurement.
- (8) Hold button: when pressing down this button, the fluxmeter is ready for signal-holding measurement.
- (9) Power supply: pressing this key will power on the fluxmeter.
- (10) “ 10^{-3} ” multiplexer, for signal sensing or holding in the rang of $0\sim 2\times 10^{-3}$ Wb.
- (11) “ 10^{-2} ” multiplexer, for signal sensing or holding in the rang of $0\sim 2\times 10^{-2}$ Wb.
- (12) “ 10^{-1} ” multiplexer, for signal sensing or holding in the rang of $0\sim 2\times 10^{-1}$ Wb.
- (13) “1” multiplexer, for signal sensing or holding in the rang of $0\sim 2$ Wb.

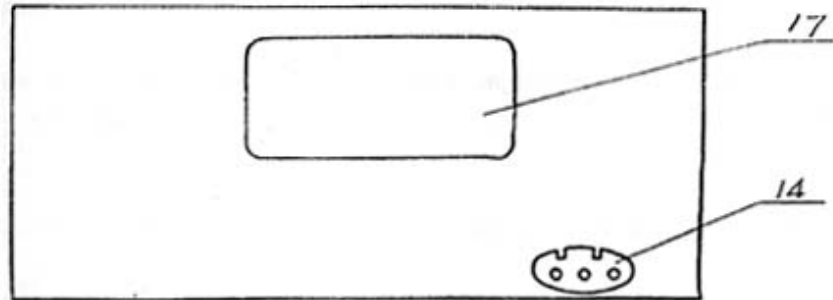

- (14) Power supply 220V AC socket
- (15) Ring coil
- (16) Oblate coil
- (17) Nameplate

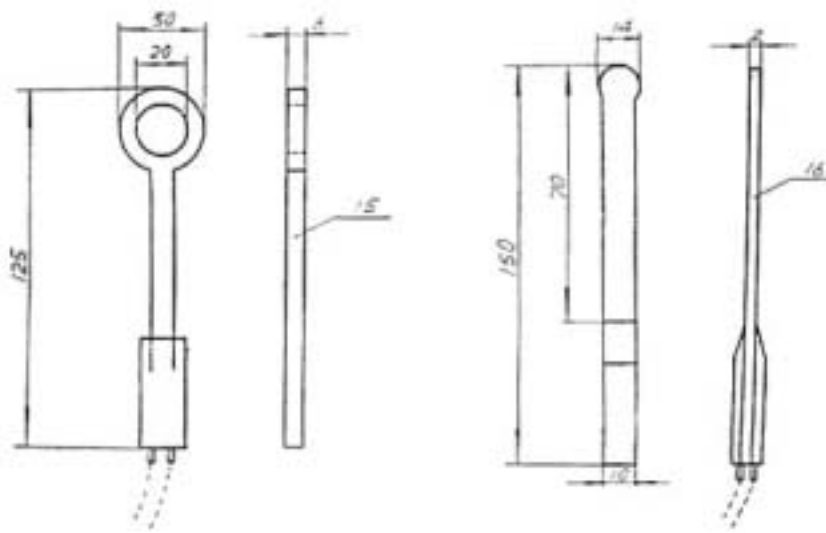

4.2 Operation Procedure

4.2.1 All buttons or keys should be related or set in “off”. Input ends should be shorted.

4.2.2 Connect the power wire to the fluxmeter, press down the power supply button and it reads ± 000 .

Note: When the multiplexers and hold button are released, the fluxmeter is ready to work.

4.2.3 Prewarming for 30 min.

4.2.4 Measurement Operation

4.2.4.1 Press down the measurement button 7 and desired multiplexer button (if the flux scope measured can not be determined in advance, please select higher multiplier to start measuring)

4.2.4.2 Zeroing

Use zero-setting potentiometer to zero to meet the stability requirement of measurement.

4.2.4.3 Measuring

- Measuring of integrated signal. Press down the resetting button, input an integrated signal to measure, and press resetting button after making sure of the reading.
- Measuring of peak-holding signal. Press down the hold button, and press resetting button, input a peak-holding signal to measure and press resetting button after making sure of the reading,

4.2.4.4 Measuring of repeating signal

4.2.4.5 If a repeating signal is to be measured, every measurement should be performed after zeroing. If another signal is to be measured, the operation should be started from 4.2.4.1.

4.3 Figure Illustration of Measurement

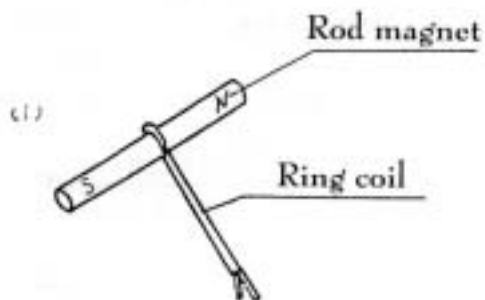

Using illustration for ring coil
Measuring by drawing coil

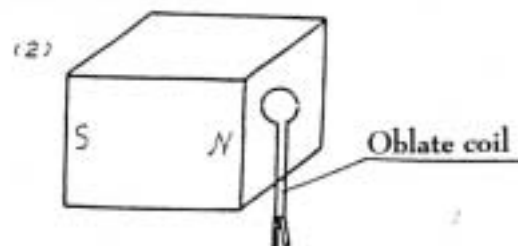

Using illustration for oblate coil
Put the coil as near as possible to the sample,
Measurement is performed by moving the
coil far away after resetting

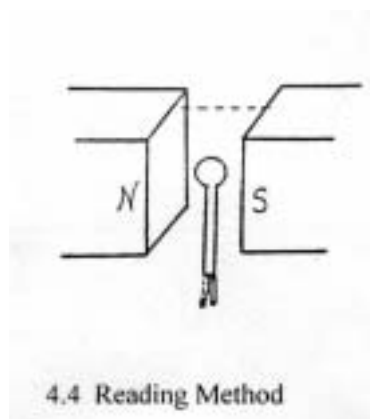

Field Measurement

Field-sensing coil (ring or oblate) should be placed perpendicularly to the direction of magnetic force line. Coil-drawing is applied for static field and coil-fixing for pulsed field.

4.4 Reading Method

Magnetic flux = display read x mWb x multiplier.

For example, if the multiplier is 10^{-2} , the read is 900, coil constant NA is 100, so that total flux and flux density can be calculated as follows:

(1) Total flux $\Phi = \text{read} \times \text{mWb} \times \text{multiplier} = 900 \times \text{mWb} \times 10^{-2} = 9.00 \times 10^{-3}$

In CGS System, $\Phi = 9.00 \times 10^{-5} \text{ Mx} \quad 9.00 \times 10^{-3} \text{ Wb}$

(2) Flux density $B = \Phi / NA = 9.00 \times 10^{-3} \text{ Wb} / 100 \times 10^{-4} = 0.9 \text{ T}$

In CGS System, $B=9000\text{G}$.

If as peak-holding measurement,

Peak-holding flux = $900 \times 10^{-3} \text{ Wb}$. $T_s = 90 \times 10^5 \text{ Mx}$. T_s .

Peak-hold flux density = $0.90\text{T} = 9000 \text{ G}$

4.5 Measurements and Calculation of Magnetic Field Strength

4.5.1 Place the Helmholtz coil in the magnetizing solenoid with the axial and radial center of the Helmholtz coil coinciding with that of magnetizing solenoid.

4.5.2 Calculation Formula

$$H = \text{Read} \times \text{multiplier} / NS \times 10^{-5} (\text{Oe})$$

While N is the turns of Helmholtz coil, S the area of Helmholtz coil in cm^2 .

If $N=10$ T_s

$$S = \pi R^2 = 3.14 \times 0.5^2 = 0.785 \text{ cm}^2.$$

$$H = \text{Read} \times 10^{-3} / 10 \times 0.785 \times 10^{-5} (\text{Oe})$$